

ELECTROSPINDLES ELETTRMANDRINI

INDEX
GLASS

Manufactured by the thousand for a large number of applications, the electrospindles for stone machining features a vast range of powers and working speeds without foregoing high levels of reliability.

Prodotti in migliaia di esemplari per molteplici applicazioni, gli elettromandrini per lavorazione del vetro sono caratterizzati da un ampio range di potenza e velocità di rotazione, senza rinunciare ad un'elevata affidabilità.



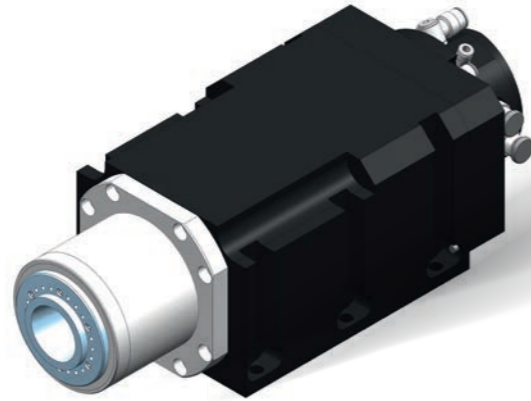

ES794

Body Diameter Diametro di centraggio	135x170 mm	
Max speed Velocità massima	16.000* rpm	12.000 rpm
Motor technology Tecnologia motore	Asynchronous	Synchronous
Torque S1/S6 (40%) Coppia S1/S6 (40%)	9.5 / 11.4 Nm	11.1 / 13.1 Nm
Power S1/S6 (40%) Potenza S1/S6 (40%)	6 / 7.2 kW	14 / 16.5 kW
Taper Attacco	ISO 40	
Cooling Raffreddamento	Liquid	

* depends on length of the spindle nose
* dipende dalla lunghezza naso mandrino

HSC

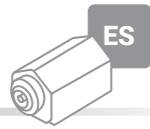

ES796

Body Diameter Diametro di centraggio	Ø 178.5 mm
Max speed Velocità massima	12.000 rpm
Motor technology Tecnologia motore	Asynchronous
Torque S1/S6 (40%) Coppia S1/S6 (40%)	31.8 / 38.2 Nm
Power S1/S6 (40%) Potenza S1/S6 (40%)	15 / 18 kW
Taper Attacco	ISO 40
Cooling Raffreddamento	Liquid
Aggregate anti-rotation flange Flangia antirotazione dell'aggregato	✓

On request:
Su richiesta:
Coolant through shaft
**Liquido di raffreddamento
attraverso l'albero**

HPC



Model Modello	<ul style="list-style-type: none"> ● Drilling/Foratura ● Milling/Fresatura ● Cutting/Taglio ● Beveling/Molatura 	MK353
Compatible with aggregates/AxC Compatibile con Aggregati/AxC	p. 28, p. 29	p. 24

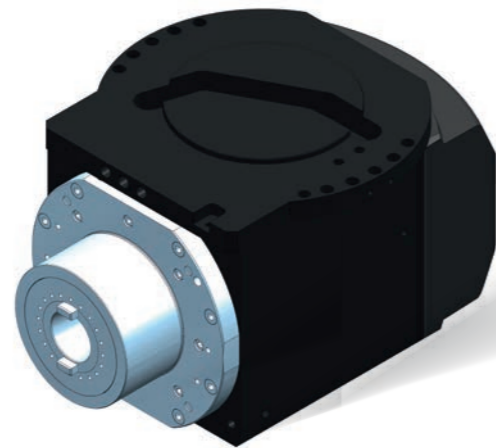

ES793

Body Diameter Diametro di centraggio	142x145 mm
Max speed Velocità massima	12.000 rpm
Motor technology Tecnologia motore	Asynchronous
Torque S1/S6 (40%) Coppia S1/S6 (40%)	31.8 / 38.2 Nm
Power S1/S6 (40%) Potenza S1/S6 (40%)	15 / 18 kW
Taper Attacco	ISO 40
Cooling Raffreddamento	Liquid

On request:
Su richiesta:
Coolant through shaft
**Liquido di raffreddamento
attraverso l'albero**



Tool fork for toolholders ISO40
Forcella utensili per portautensili ISO40



Pullstud for ISO 40 HSD toolholder
Codolo per portautensili ISO40



Pullstud for CAT40 HSD toolholder
Codolo per portautensili CAT40



ES796 waterflange unit
Gruppo waterflange ES796



ES796 housing unit
Gruppo housing ES796



Water refrigerator (chiller)
Refrigeratore acqua (chiller)

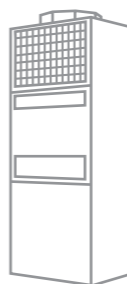

Water/air heat exchanger
Scambiatore di calore acqua/aria